



PRODUCT SPECIFICATION

Product Name: Piezo Buzzer

Part Number: MSPS30B32W100V12

Document No: _____

Date: 2021.05.22

DRAWING BY	CHECKED BY	APPROVED BY
CHEN YUAN	YUE QIN	JIN LI

1.SPECIFICATION

NO.	Item	Unit	Specifications
1-1	Rated Voltage	VDC	12
1-2	Operating Voltage	VDC	6-16
1-3	* Min Sound Output at 10cm	dB	105
1-4	* Rated Current (Max)	mA	30
1-5	* Resonant Frequency	Hz	3250±500
1-6	Tone Nature		Singe
1-7	Operating Temperature	°C	-40~+85
1-8	Storage Temperature	°C	-40~+85
1-9	Weight	g	6.0
1-10	Housing Material		ABS777D(Black)
1-11	Lead Wire		UL1571 28AWG

2.ENVIRONMENTAL TEST

NO.	Item	Specifications
2-1	Storage in High temp.	Storage in +70°C±2°C test box for 240 hours , then expose to the room temperature for 2 hours without applying power.
2-2	Storage in Lower temp.	Storage in -30°C±2°C test box for 240 hours , then expose to the room temperature for 2 hours without applying power.
2-3	Storage in Humidity	Storage in +30°C±2°C 90-95%RH test box for 96 hours, then expose to the room temperature for 2 hours without applying power.
2-4	Thermal cycle test.	<p>Make this test for 5 cycles without applying power,then expose to the room temperature for 2 hours.</p>
2-5	Vibration test	<p>Amplitude:1.5mm Time :1min/axis</p> <p>Make this test for the directions of X,Y, Z for 2 hours each (total 6 hours).</p>
2-6	Drop test	Free drop a unit from the height 100cm to the surface of 10mm thick board ,three directions(X,Y,Z).

PASS CRITERION :

After these tests , the change of S.P.L shall be within ±5 dB .

3.MEASURING METHOD(BUZZER MODE)

3-1 .Test Condition

3-1-1.STANDARD

Temperature : 25±3°C

Relative humidity : 60% ~ 70%,

Atmospheric pressure : 860mbar to 1060mbar

3-1-2.JUDGEMENT

Temperature : 15 ~ 35°C

Relative humidity : 45% ~ 85%,

Atmospheric pressure : 860mbar to 1060mbar.

3-2 . Standard Test Fixture

1.rated Voltage: 9V

2.Resonant Frequency: 3200Hz±500

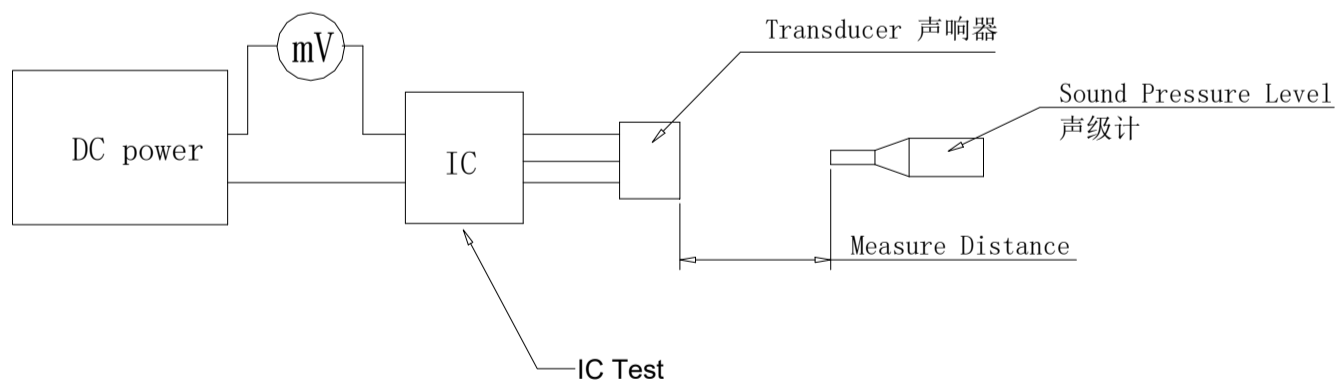
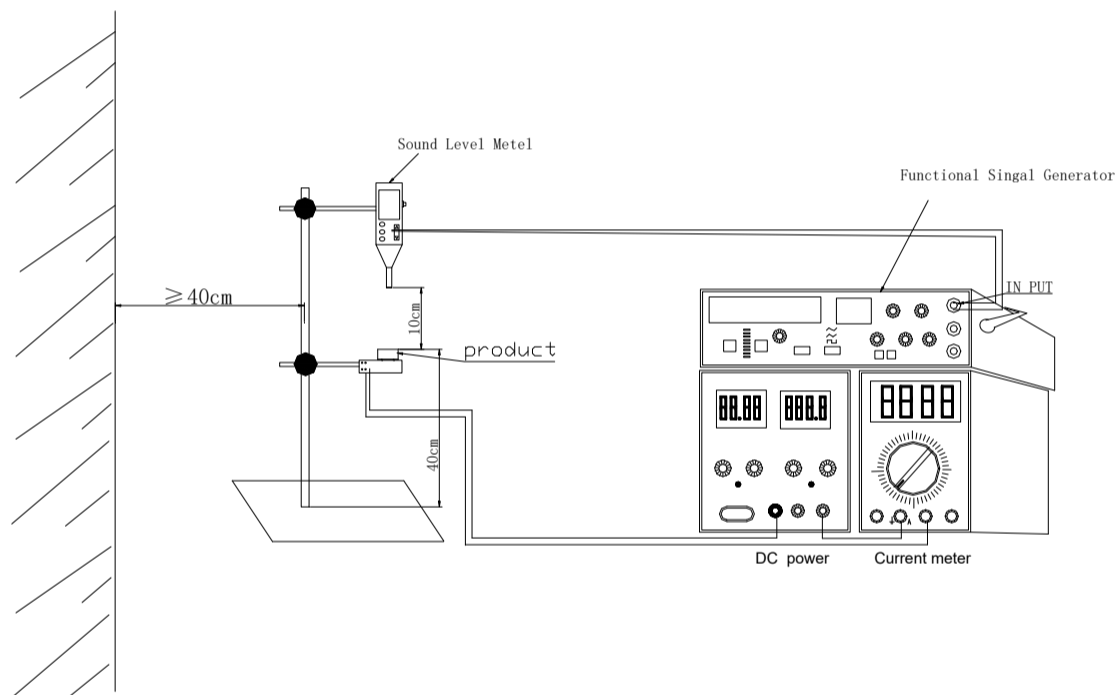

4.DIMENSIONS

Unless otherwise specified,tolerance:±0.5(unit:mm)

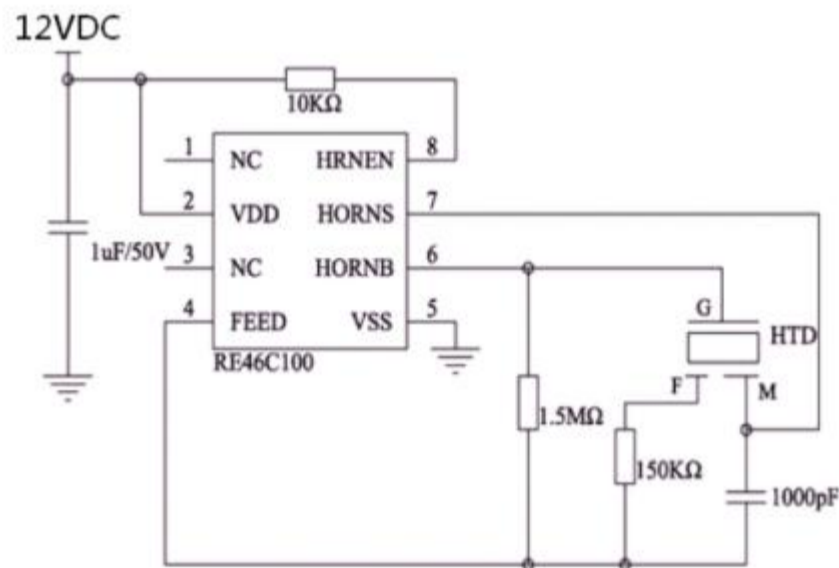
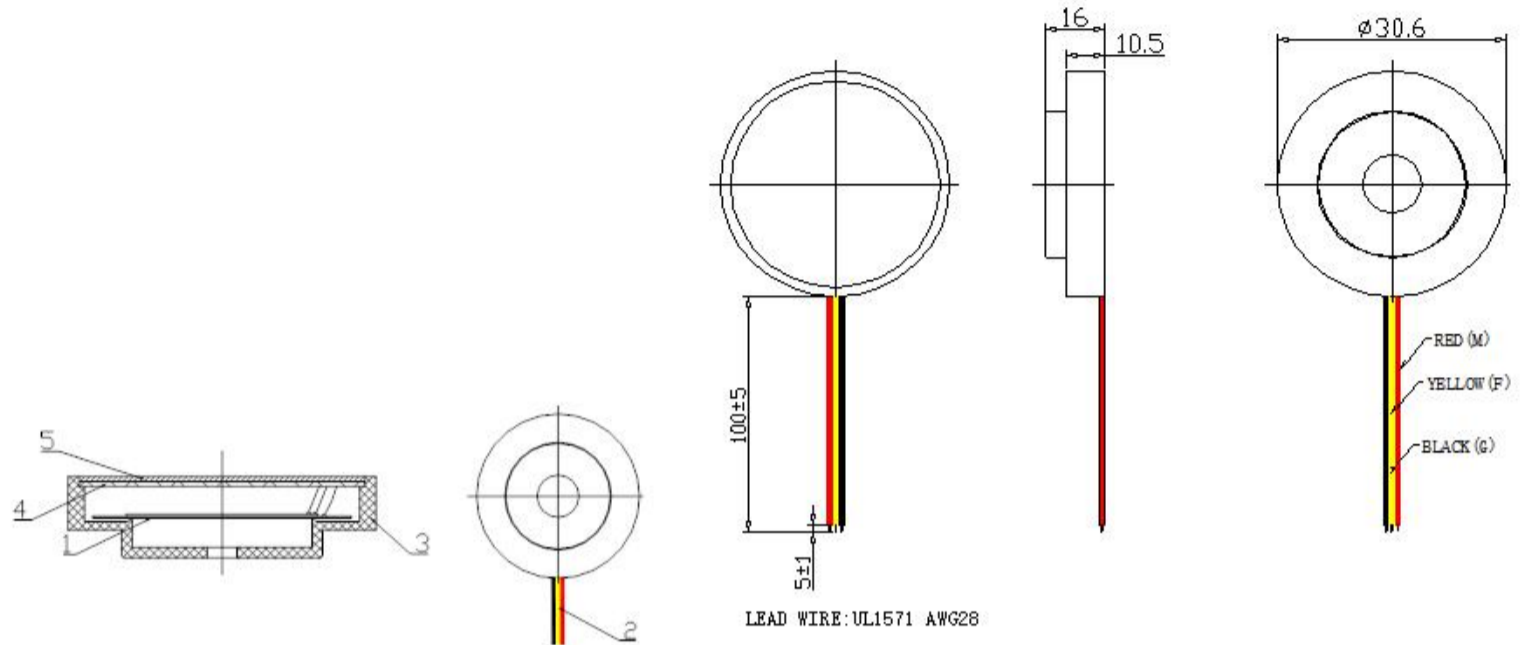

1)All parts must be meet to ROHS.

5	Cover	1	BLACK ABS777D	
4	PCB	1	Epoxy Board	
3	Housing	1	BLACK ABS777D	
2	Lead Wire	2	BLACK&RED&YELLOW(UL1571 28AWG)	
1	Piezo element	1	Brass	
Part No.	Part Name	Q'TY	Material	Remark

5.PACKING

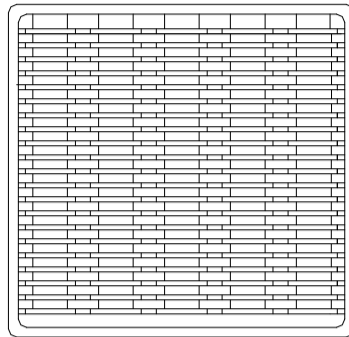

每盒放50只。
泡沫盒尺寸：250*240*51.5mm

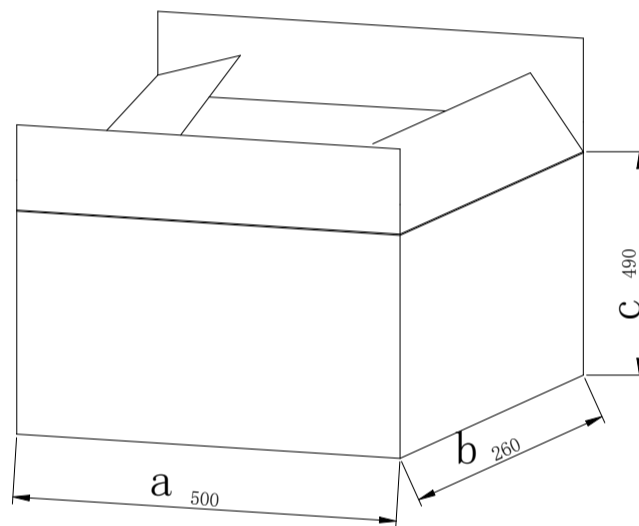

每箱放1000只。
纸箱尺寸：500*260*490mm