

**DESCRIPTION:** Ultrasonic Sensor  
**MODEL:** MSO-A1625H12R

### FEATURES

Receiver: "R" mark on housing  
 Compact and light weight.  
 High sensitivity and sound pressure  
 Less power consumption  
 High reliability

**PICTURE:**



### SPECIFICATIONS

Item	Value
Using method	Receiver
Center frequency	24±1KHz
Sensitivity for receiver	≥-65dBV/μMbar
Directivity	80deg
Capacitance	2600pF±20%@1KHz
Operating temperature	-30 to +85°C
Measure distance	0.2~12m
Metals of case	Aluminum
Weight	2.31g

### MECHANICAL DRAWING

units:mm

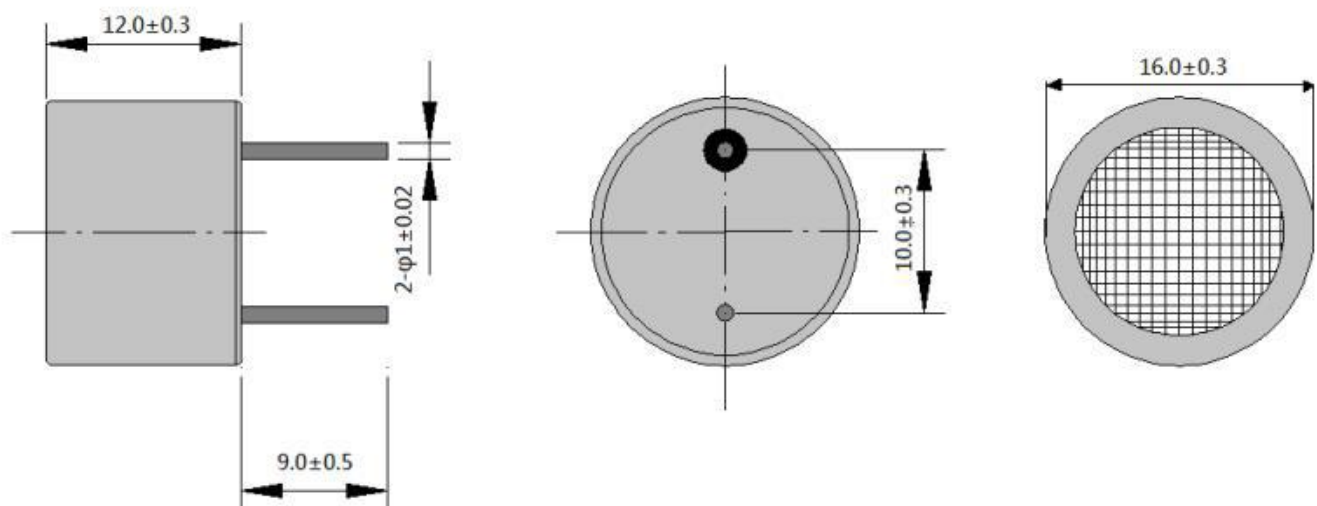

## BEAM ANGLE

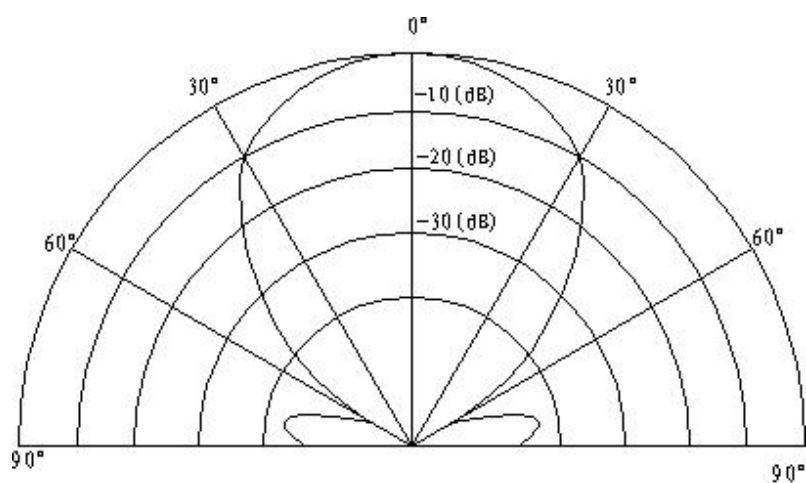

Directivity in Overall Sensitivity

## TEST CIRCUIT

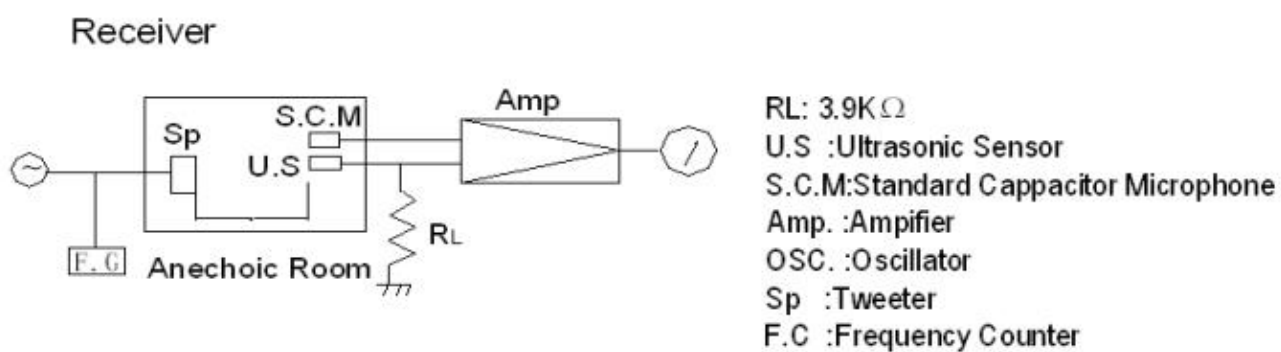

## PACKAGING DETAILS

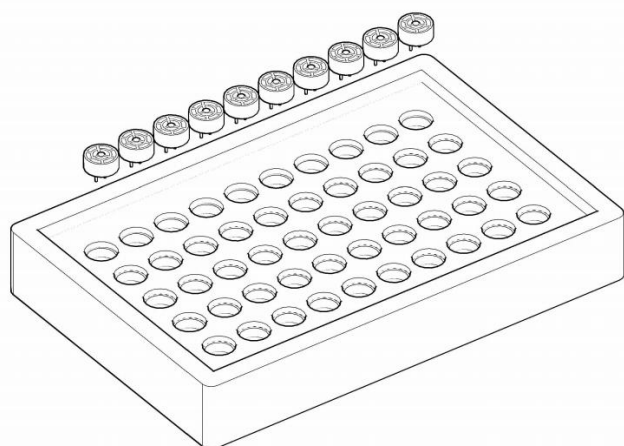

50PCS/BOX  
 BOX SIZE:24\*16\*3CM

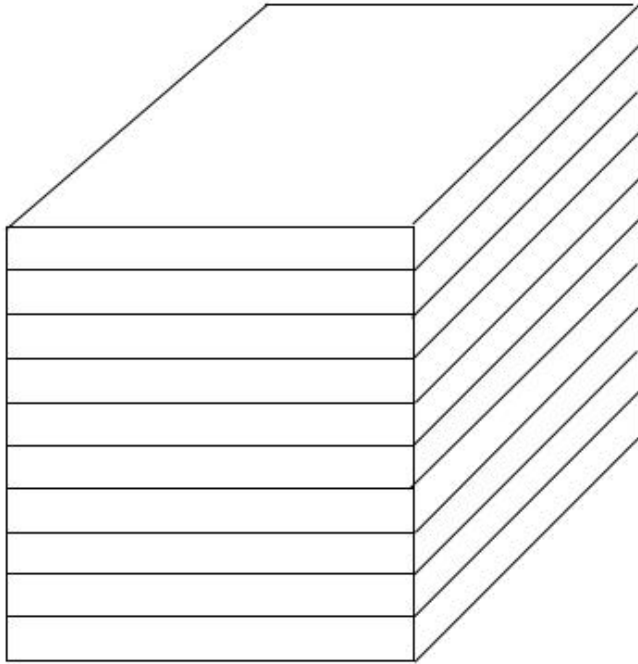

10BOXES/STACK, TOTAL 500PCS  
STACK SIZE:24\*16\*24CM

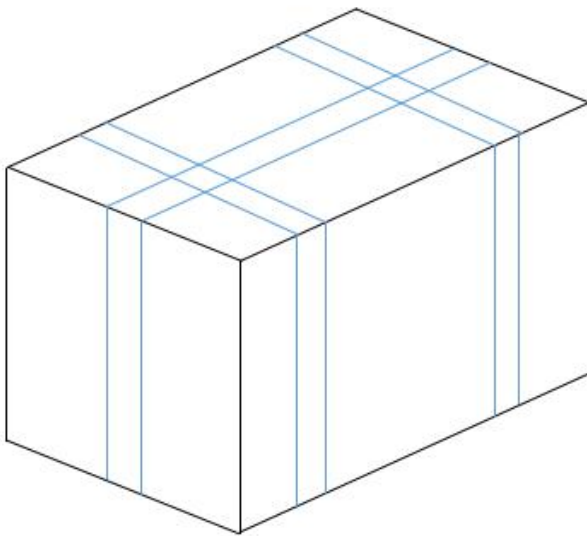

2000PCS/CARTON  
CARTON SIZE:48\*28\*32CM